

# USRA BOXCAR

## Single Sheathed

Era: 1918-1950's

KIT #4026

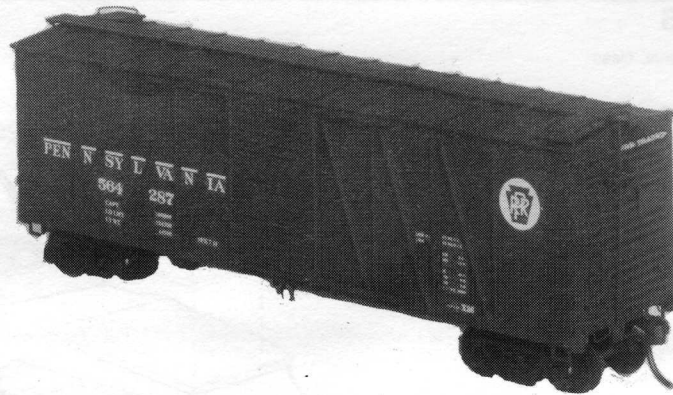

### INTRODUCTION

Long a favorite of modelers, this USRA design 50 ton single sheathed boxcar was also a favorite of its' era — 1918-1950's. References indicate that some 25,000 were built for twenty one railroads, by thirteen carbuilders. The railroad with the largest number of cars was the Pennsylvania, followed by the Chicago, Milwaukee and St. Paul. They were durable cars with a long life; in later years many variations resulted from rebuild programs.

This kit is an accurate "as-built" representation, with Andrews trucks, type K brake gear and vertical brake staff. The many published photos show variations that include Ajax brake gear (included in kit as modeler option), type AB brakes, and Bettendorf trucks. Andrews are included, but the later Bettendorf are also part of our product line.

Decals are not included, but are available from Walthers. These are listed as: B&O, 934-26140, C&O, 934-35110, C&NW, 934-38160, NYC, 934-71110, PRR, 934-77150, SP, 934-89131. Others are being added constantly, so check the Walthers catalogue for your favorite. The proper color would be Tuscan or Boxcar Red.

Due to the large amount of underbody detail we find it easier to assemble carbody, ends, and floor as one unit, rather than a separate underbody as with other kits. If you plan to have working or open doors you may want to pre-paint the interior and floor section prior to assembly, as they are usually a lighter wood color. The doors do operate, but are somewhat fragile due to scale detail — many modelers will simply cement them in place, either closed, or partially open. It's your choice. Assembly Stand C-14 is provided — just press them into the bolsters after the underframe is completed to protect the detail and assist during assembly and painting.

Reference: MAINLINE MODELER, July/August, 1980  
MODEL RAILROADING, various issues with many photos.

This is a fun kit of distinctive prototype, so let's get started . . .

### PLEASE READ BEFORE ASSEMBLY

Each 'sprue', or group of parts, has an identification number and letter molded adjacent to the part. Example, A-3. Each part is attached to the sprue by a small 'gate' — when removing a part cut close to the sprue, then carefully trim the gate flush to the part. Do not twist the part off, and remove the part only when called for in the instructions to avoid confusion.

We recommend only "liquid cement for plastics" for assembly. Use ACC for plastic to metal joints. Test fit each part to see where cement should be applied, then do so with a small pointed brush, allowing cement to draw into joint by capillary action. Tack larger parts first for position, then flow cement into joint. Tacking can be compared to 'spot welding'. Be careful not to allow cement to flow under your fingertips.

Clean your workspace before starting, provide adequate lighting, and work over a clean sheet of white paper for contrast. And remember — the most common problem is tipping over the cement bottle!

### PARTS LIST

Quantity needed in ( )	Part Number	Description
(1)	4026-A-1	FLOOR
(1)	A-2	CENTERSILL
(1)	A-3	CENTERSILL
(1)	4026-B-1	CARBODY/ROOF
(2)	4026-C-1	DOOR CROSSBEARER
(10)	C-2	CROSS-SILL CHANNELS
(2)	C-3	TACKBOARD
(4)	C-4	ROOFWALK SUPPORT
(4)	C-5	STIRRUP STEP
(2)	C-6	TRUCK WASHER
(2)	C-7	LOWER DOOR TRACK
(2)	C-8	UPPER DOOR TRACK
(2)	C-9	WOOD DOOR
(2)	C-10	STEEL DOOR
(4)	C-11	DOOR GUIDE PLATES
(2)	C-12	ROOF CORNER PLATFORM
(2)	C-13	BODY BOLSTER
(2)	C-14	ASSEMBLY STAND
(1)	4026-D-1	ROOFWALK
(1)	D-2	B END
(1)	D-3	A END
(2)	D-4	COUPLER POCKET COVER
(1)	D-5	DRILL JIG
(1)	D-6	BRAKE CYLINDER MOUNT
(2)	D-7	BRAKE LEVER SUPPORT, LARGE
(1)	D-8	BRAKE LEVER GUIDE, SMALL
(1)	D-9	BRANCH LINE PIPE
(1)	3005-K-2	BRAKE CYLINDER
(2)	K-5	BRAKE PLATFORM SUPPORT
(1)	K-11	BRAKE PLATFORM w/ratchet & pawl
(1)	K-14	BRAKE WHEEL
(1)	K-19	BRAKE LEVER, LONG
(1)	K-20	BRAKE LEVER, SHORT
(1)	K-21	UPPER BRAKE STAFF SUPPORT
(1)	K-22	LOWER BRAKE STAFF SUPPORT
(2)		ANDREWS TRUCKS by Tichy
(2)		2-56 self tapping screws
(2)		HEX-NUT WEIGHTS
1 length,		.010 wire, brake rods
1 length,		.020 wire, train line/brake staff

## 1 TRUCKS

- 1) Remove **SIDEFRAMES** and **BOLSTER** from sprue, trim gates and sucker pin from top of sideframe.
- 2) See illustration: with 'pat.pend' up, snap bolster pin and hooks into sideframe. **DO NOT REMOVE ONCE ASSEMBLED**, as this will damage hooks. Do both sideframes.
- 3) SET ASIDE for fifteen minutes to allow the plastic memory to recover.
- 4) Gently rotate sideframes in opposite angles and carefully insert wheelsets, return to normal position.
- 5) The trucks are molded in a specially formulated Teflon® loaded acetal plastic. The Teflon® will migrate to the surface during use resulting in an extremely free-rolling truck. Start this process by rolling the trucks across your workbench several times with moderate pressure on the bolster — this will result in excellent break-in.

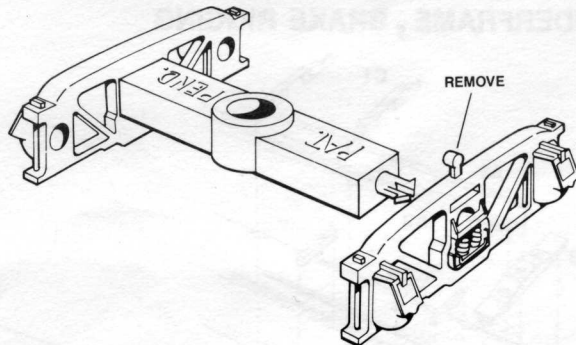

IGNORE IF KIT HAS ONE PIECE TRUCKS

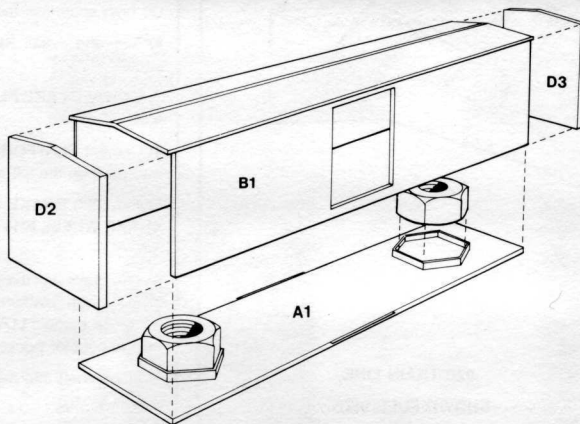

## 2 PRELIMINARY ASSEMBLY

- 1) Trim sprue on carbody roof.
- 2) Remove **FLOOR A-1** from sprue, clean up gates, smooth edges with a flat file.
- 3) Test fit floor into **CARBODY** — trim ends of extended scribed portion of floor to fit door opening if necessary.
- 4) When all fits well, remove floor. Cement **HEX-NUT WEIGHTS** in place with ACC cement. Set floor aside — do not cement into body at this time.
- 5) Remove **ENDS D-2** and **D-3** from sprue, carefully scrape or file draft angle from top edges to allow tight fit under roof. For added realism, slightly round outside corners of ends with a modelers knife. Do not round poling pockets.
- 6) Drill grabiron holes in ends #79. (.0145).
- 7) Cement one end to carbody (careful with those little tabs!) Hold until cement has set.
- 8) Cement other end in place.
- 9) Cement small diagonal tabs tight against ends with a tiny drop of cement and a blunt pointed tool.

Note: Be careful not to damage small diagonal tabs on ends when handling carbody molding.

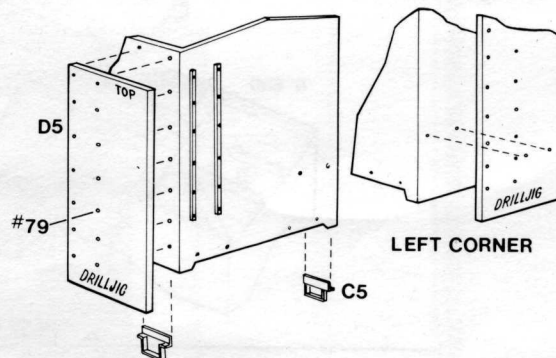

- 10) Trim doorstops at a 45° angle if desired for a better appearance.

## 3 CARBODY

- 1) With floor on edge, test fit again for length, file as necessary.
- 2) Note "B" end — it is engraved on inside of end with four small holes to locate brake platform.
- 3) Note "B" end of underframe — it is engraved between the grooves that locate the centersills.
- 4) Orient B end of underframe and B end of carbody — gently spread door area of carbody and insert floor. When located, cement in place, making sure carbody is tight against floor.
- 5) Drill #79 (.0145) through spotted locations on **DRILL JIG D-5**.
- 6) Place drill jig against side, locating rib against end, with "top" tight under roof overhang. Spot drill #79 to establish location, remove jig, then drill through or to about 3/32" deep. Don't forget the two holes located on the left side of car.

## 4 UNDERFRAME , BRAKE RIGGING

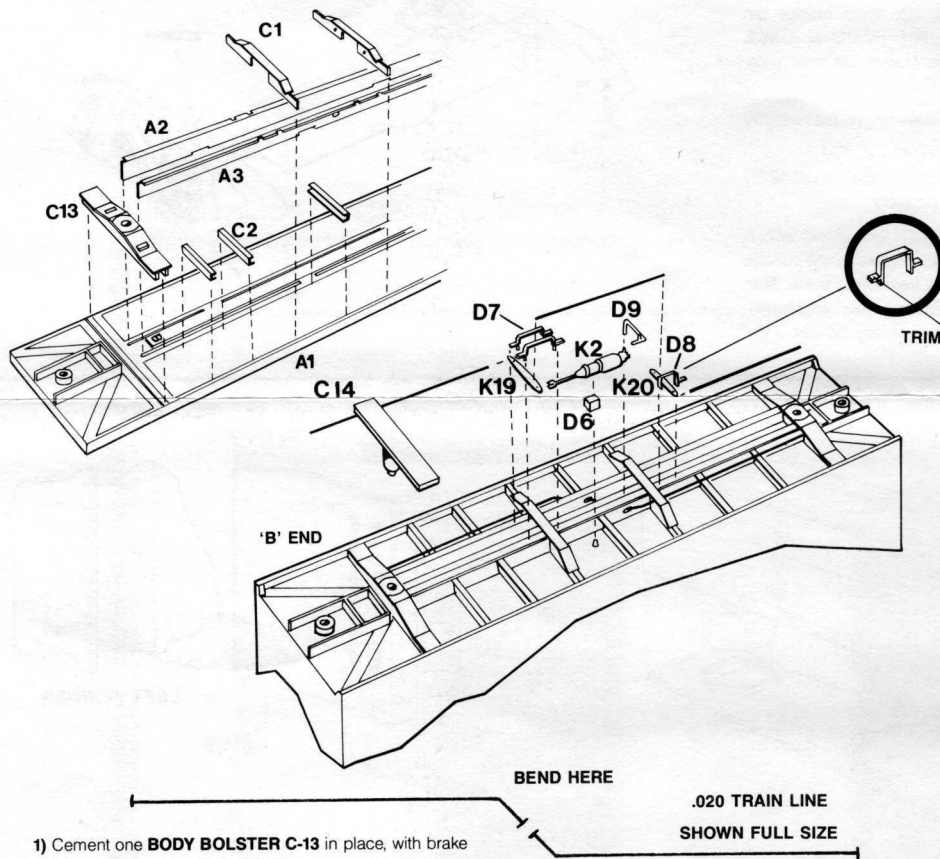

1) Cement one **BODY BOLSTER C-13** in place, with brake rod locators toward center of car.

2) Cement **CENTER SILLS A-2** and **A-3** in place, noting locators and that flange faces out. Make sure sills are bottomed in slots and square.

3) Cement other **BODY BOLSTER C-13** in place.

4) Ream two holes in each **DOOR CROSSBEARER C-1** with #73, (.0200) drill, to provide clearance for trainline.

5) Install **DOOR CROSSBEARERS** by snapping over center sill, and located against molded flange. See illustration. Flange on crossbearer face toward center of car. Trim open small square locator molded in center sill for later location of brake support bracket.

6) Install 10 **CROSS-SILL CHANNELS C-2** as shown—flanges face center of car, except for the center channels, which face the B end.

7) Bend and cut **TRAINLINE** from .020 wire provided. Install as shown with ACC cement. Long end of line should be cemented just under the flange on body bolster.

8) Cement **BRAKE CYLINDER BRACKET D-6** over post molded on floor, with 'V' groove parallel to car.

9) Cement **BRAKE CYLINDER K-2** to bracket, with clevis pointing to B end.

10) Install two **LEVER SUPPORTS D-7** as shown.

11) Remove small tab from **LEVER SUPPORT D-8** to clear flange on door crossbearer—install as shown.

12) Cement **LONG BRAKE LEVER K-19** to clevis, with lever at right angle to car and brake rod clevis pointing to end of car.

13) Cement **SHORT BRAKE LEVER K-20** to pad on center-sill, and brake rod clevis pointing to end of car, and at right angle.

14) Install .010 brake rods as shown with ACC cement.

15) Install **BRANCH LINE PIPE D-9** between dirt collector on end of brake cylinder and small cup molded between centersills.

16) Press **ASSEMBLY STANDS C-14** into bolster holes—this will protect carbody during further assembly and painting. If loose, knurl with a pair of pliers for a tight fit.

## 5 ROOFWALK-PLATFORMS

- 1) Carefully remove **ROOFWALK D-1** from sprue, clean gates and flash.
- 2) Wet one roofwalk support at each end of roof with cement, locate roofwalk by eye, centering on ribs and with boltheads centered.
- 3) Apply tiny drop of cement at each support — cement will draw into joint.
- 4) Ream two holes in each **CORNER PLATFORM C-12** with #79 drill. Do not trim off small corner post.
- 5) Cement platform to each end — note location from drawing.
- 6) Cement **ROOFWALK SUPPORTS C-4** to each end.
- 7) Cement **TACK BOARDS C-3** to each end as shown.

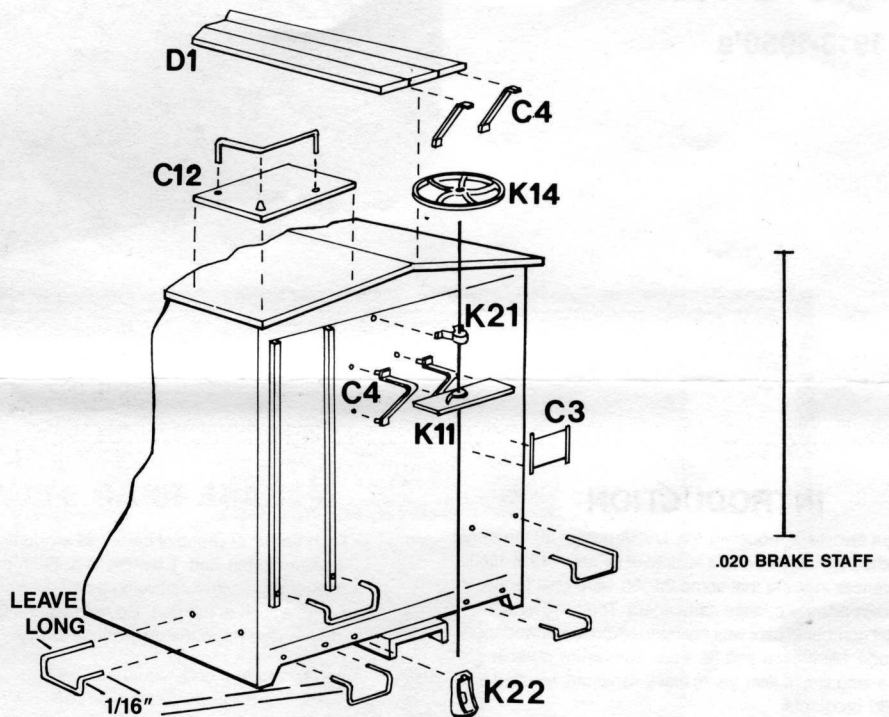

## 6 GRABIRONS-BRAKE DETAIL

- 1) Trim and install **GRABIRONS** as shown with ACC cement. Do both ends first, then sides.
- 2) Trim and install **PLATFORM CORNER GRABS** (pre-formed wire).
- 3) Cement **BRAKE PLATFORM BRACKETS K-5** to locator holes on B end.
- 4) Cement **PLATFORM** with **RATCHET K-11** to brackets, with pawl on the left and ratchet wheel on right.
- 5) Trim .020 **BRAKE STAFF** wire to length, ream hole in **BRAKE WHEEL K-14** with #76 drill — cement wheel to shaft with ACC.
- 6) Run brake staff through **UPPER SHAFT SUPPORT K-21** and through platform. With shaft parallel to ladder for reference, cement **LOWER SHAFT SUPPORT K-22** to end next to coupler pocket.
- 7) Insert shaft into molded cup on lower support, affix with ACC.
- 8) Although shown here, you may wish to install **STIRRUP STEPS C-5** just prior to painting.

Because of the small size no retainer valve is included — model this if you wish with a tiny piece of .010x.010 styrene, and route the .005 retainer pipe as shown in your prototype photos. There are many variations to this, and the location varied.

## 7 DOOR DETAIL

- 1) Carefully remove **UPPER DOOR TRACK C-8** from sprue. See illustration, then cement in place above door, tight under the roof overhang.
- 2) Choose either as-built **WOOD DOOR C-9**, or later **STEEL DOOR, C-10**. Trim gates from top of door, but do not remove the small gate extensions or lip on door.
- 3) Cement two **DOOR GUIDE PLATES C-11** to recesses on back of door.

NOTE: Prepare **LOWER DOOR TRACK C-7** at this time. Set aside with doors and paint at same time as carbody. Follow steps 4-6 after paint has dried, scraping paint from areas to be cemented. If non-operating, proceed . . .

- 4) Insert door into upper door track.
- 5) Insert lower door track into door guides.
- 6) Cement lower door track to carbody.

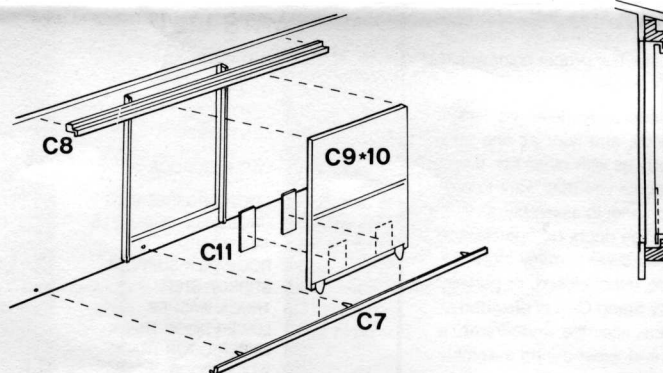



# USRA BOXCAR

## 50 ton, Single Sheathed

### KIT #4026

#### 8 FINAL ASSEMBLY

- 1) Paint and letter car to your choice — let it dry completely.
- 2) Remove assembly stands.
- 3) Install couplers using **COUPLER POCKET COVERS D-4**. They can be cemented or snapped in place.
- 4) Screw **TRUCKS** in place with self-tapping screws provided. If using **TICHY** or **ATHEARN** trucks, use **TRUCK WASHER C-6** to provide correct coupler height. If using **KADEE®** trucks omit washer.
- 5) Apply final weathering and send it out on revenue service!

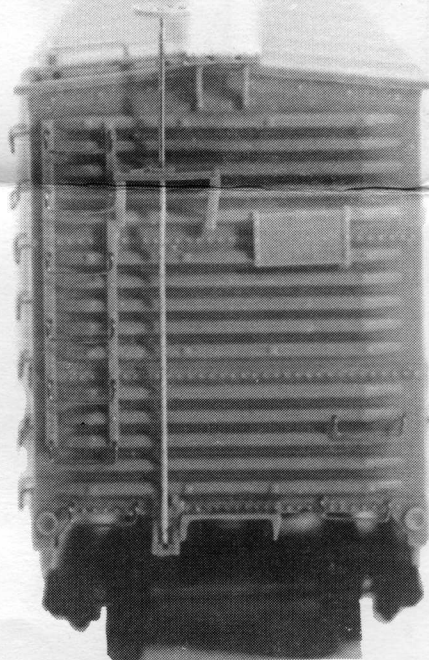
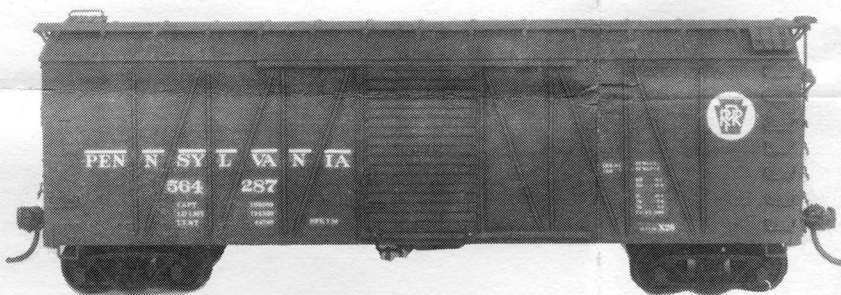
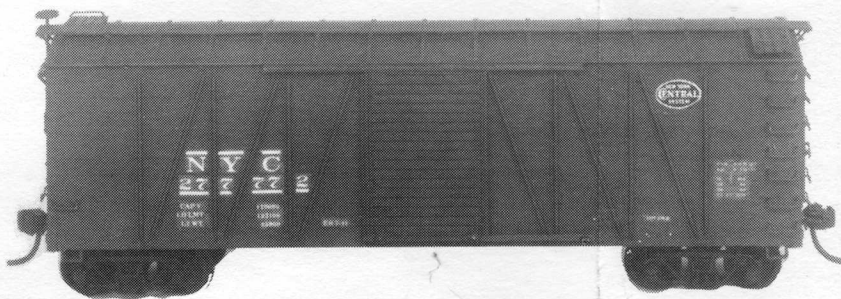

**TICHY TRAIN GROUP**  
PO BOX 220  
ALAMANCE NC 27201-0220  
[WWW.TICHYTRAINGROUP.COM](http://WWW.TICHYTRAINGROUP.COM)

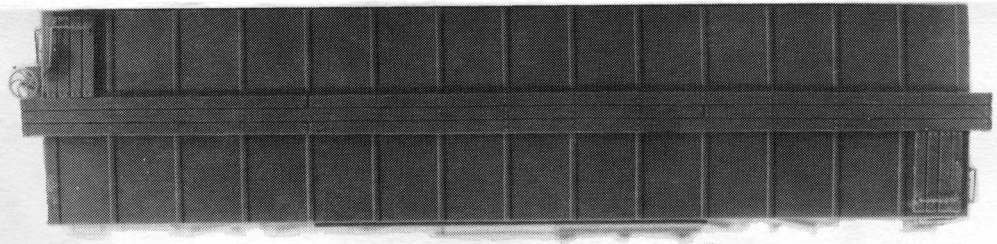
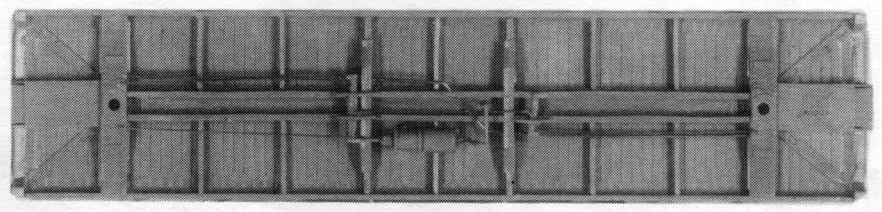
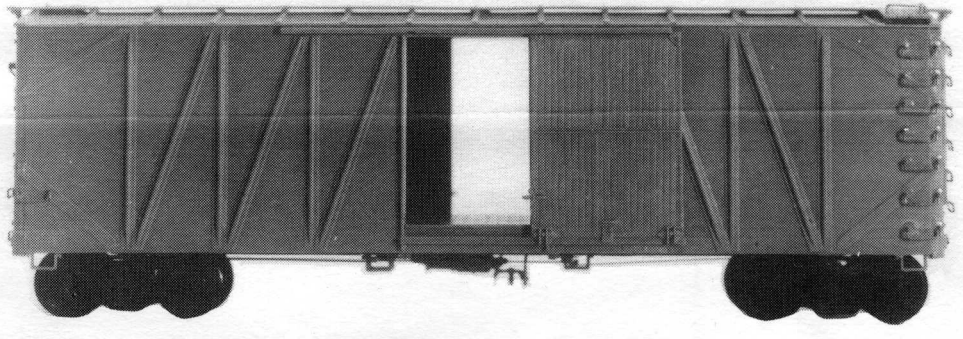
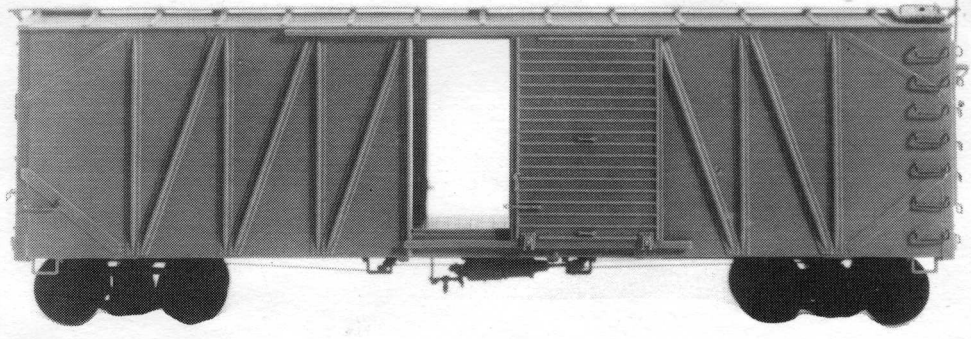

If you should irreparably damage or lose a part it will be replaced without charge. Please return the part/s to us with \$1.50 for shipping and handling — a replacement will be sent immediately. And, do drop us a line, we enjoy hearing from you with ideas, comments and suggestions for new products.

Copyright © 1989, TICHY TRAIN GROUP. All rights reserved. Any duplication of this kit or any of the component parts directly or indirectly, by rubber, wax, plastic or any other reproductive media for commercial purposes is expressly prohibited without consent in writing from TICHY TRAIN GROUP.

**TICHY  
TRAIN  
GROUP**

Made and printed with pride in the UNITED STATES OF AMERICA

18 KENNEDY DRIVE, HALFPASS, NY 11743

# KIT 4030

# USRA CEMENT CAR

FOLLOW THE INSTRUCTIONS FOR THE STANDARD USRA BOXCAR (#4026) WITH THE FOLLOWING EXCEPTIONS:

DELETE SECTION 1 - 1 PIECE TRUCKS ARE SUPPLIED.

SECTION 4: DO 1,2,3,5&6 THEN:

GLUE 4 HOPPERS IN PLACE WITH VERTICAL WALLS FACING THE CENTER OF THE CAR. CAR. NOTE THERE ARE LEFT & RIGHT UNITS. REFER TO PHOTO.

GLUE SLIDE GATES ONTO HOPPERS FACING THE OUTSIDE OF THE CAR. USE PLENTY OF SOLVENT AS THESE ARE A TIGHT FIT.

GLUE LONG REINFORCING STRIPS UNDER EACH SIDE CENTERED UNDER THE DOOR. AT "B" END OF CAR MOUNT THE SPLIT K BRAKE COMPONENTS. THEY SIT ON THE SPACER BLOCKS MOLDED IN THE CENTER OF THE HOPPER SPRUE. INSTALL LEVERS AND RODDING AS PER PHOTOGRAPH. AS SHOWN IN THE PHOTOGRAPHS THE TRAIN LINE RUNS AROUND THE HOPPERS UNDER THE EDGE OF THE CAR.

SECTION 5: COMPLETE THIS SECTION AND THEN GLUE ROOF HATCHES IN PLACE AS PER PHOTOGRAPHS.

COMPLETE CAR REMEMBERING TO INSTALL THE GRABIRONS IN THE ROOF HATCHES WHEN INSTALLING GRABS.

